



Setting a Global Standard



www.dril-quip.com

Template Systems

OVERVIEW

When water depths are shallow, production wells can be spotted and drilled randomly relative to one another. In deeper water and more remote locations, production wells are clustered and directionally drilled to gain access to the largest part of the reservoir.

DRIL-QUIP template systems provide the operator with the ability to arrange production wells in a pattern. This eliminates the possibility of intersecting wells or well misalignment by forcing direct centerline-to-centerline well spacing. All DRIL-QUIP template systems come with the required alignment and concentricity accessories to facilitate vertical installation of equipment during the drilling phase, and also provide trouble-free operations during the tie-back phase.

DRIL-QUIP template systems consist of the following:

- Unitized Template Systems
 - Conductor-Supported Template Systems
 - Bottom-Supported Template Systems
- Modular Template Systems

All DRIL-QUIP template systems are available with bumper-guide receptacles, which can be used to align the jacket and its bell guides with the template well receptacles, ensuring proper alignment. Each bumper-guide receptacle is removable prior to jacket installation. This helps to eliminate the possibility of load shock to the template and predrilled wells during jacket installation.

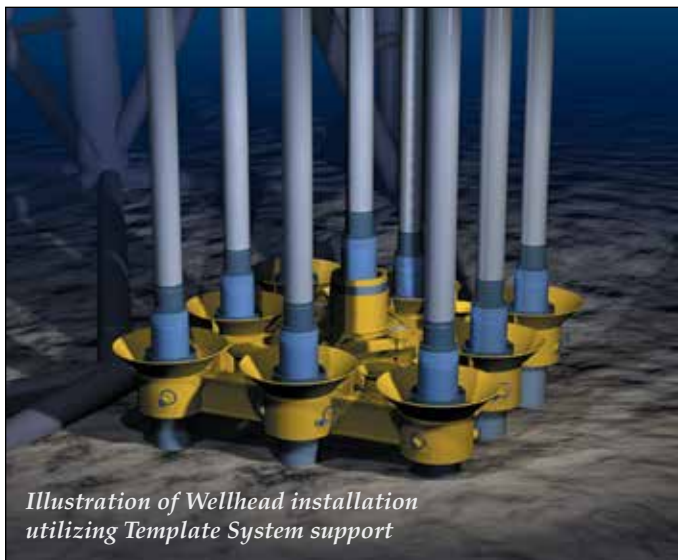
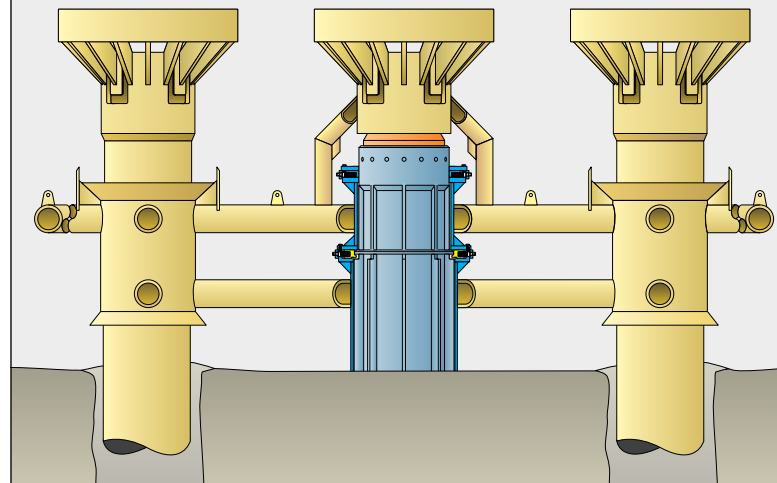

Illustration of Wellhead installation utilizing Template System support

Template Systems Advantages

- Predrilling during jacket construction provides early cash flow
- DRIL-QUIP offers flexible template designs, engineered according to customer specifications
- Quality material selection provides the strongest possible template system
- Certified welders and certified welding procedures ensure a quality product
- Qualified and trained field technical representatives are available 24 hours to assist in template installation

Illustration of a Conductor-Supported Template



Operational Advantages

- Systems are designed to stand up to the effects of drilling operations
- Retrievable bumper-guide receptacles provide jacket alignment and tie-back alignment
- Each bumper-guide receptacle is removable, helping to eliminate load shock to the template structure
- All disconnect points can be set at the same distance from the mudline
- Tight centerline-to-centerline control of individual conductors in multi-well template systems

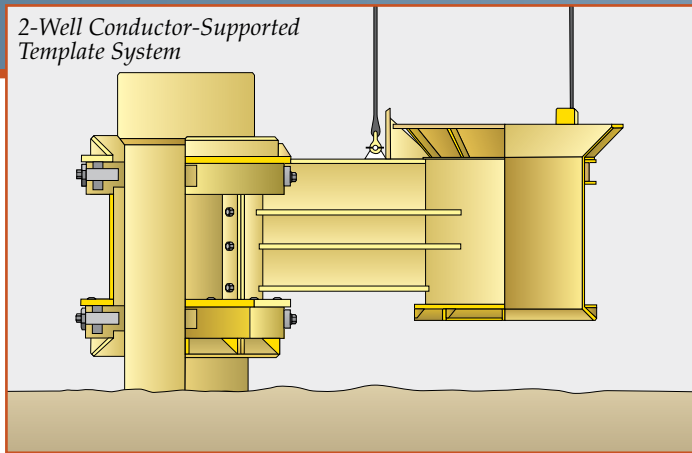

Designed and Tested to Optimize Field Performance

The DRIL-QUIP template system design can be tailored to suit specific customer requirements. Each template system is subjected to computer nodal analysis to ensure its suitability for the drilling environment. Computerized finite element analyses are conducted on areas of expected high loads. This is how DRIL-QUIP's template systems combine drilling technology and production requirements with operational advantages to supply the operator with the latest innovations available in template design at a realistic cost.

Quality Manufacturing Process and On-Time Delivery

DRIL-QUIP has dedicated itself to quality in order to supply consistent equipment performance required in the harsh subsea environment. Only quality materials are selected, and ASME-qualified welding procedures and certified welders are used in the fabrication of each template.



3-Well Bottom-Supported Template System being readied for immersion

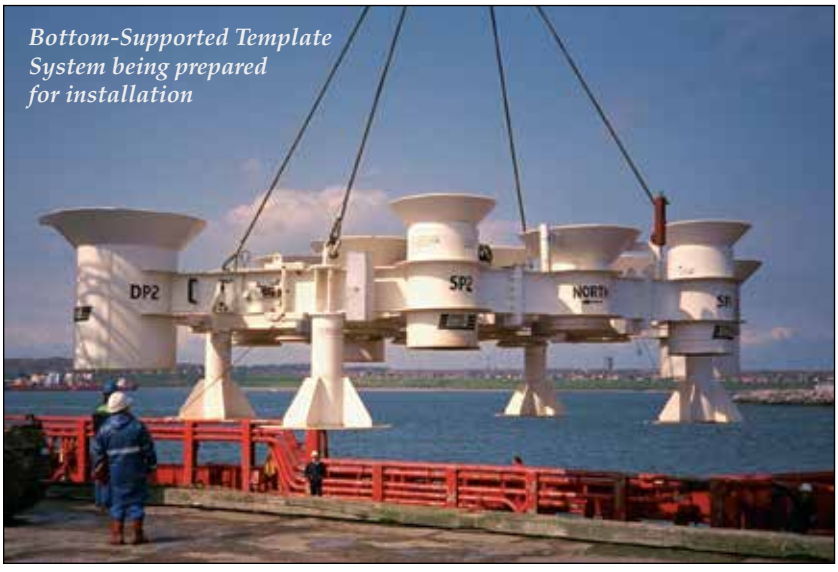

Bottom-Supported Template System being prepared for installation

Quality control checks are performed at preset stages of the manufacturing process, and a complete fit-and-function test is performed after the manufacturing and assembly processes are completed. Plus, continuous monitoring of individual orders assures on-time deliveries.

Field Service

Specially trained DRIL-QUIP service representatives are stationed at various locations worldwide and are available on a 24-hour on-call basis to assist the customer in the specification, handling and running of each DRIL-QUIP product.

UNITIZED TEMPLATE SYSTEMS

DRIL-QUIP Unitized Template Systems are manufactured from quality steel tubes that incorporate a number of slots, depending on the specifications. Unitized Template

Systems can be either conductor-supported or bottom-supported, and can be designed and configured for jack-up or subsea drilling and completion operations.

Conductor-Supported Template Systems

Conductor-Supported Template Systems are used where ocean floor conditions are known to be unstable and predrilling could undermine the template foundations. The Conductor-Supported Template System is also used in areas where the ocean floor is heavily inclined. A maximum of nine wells is recommended.

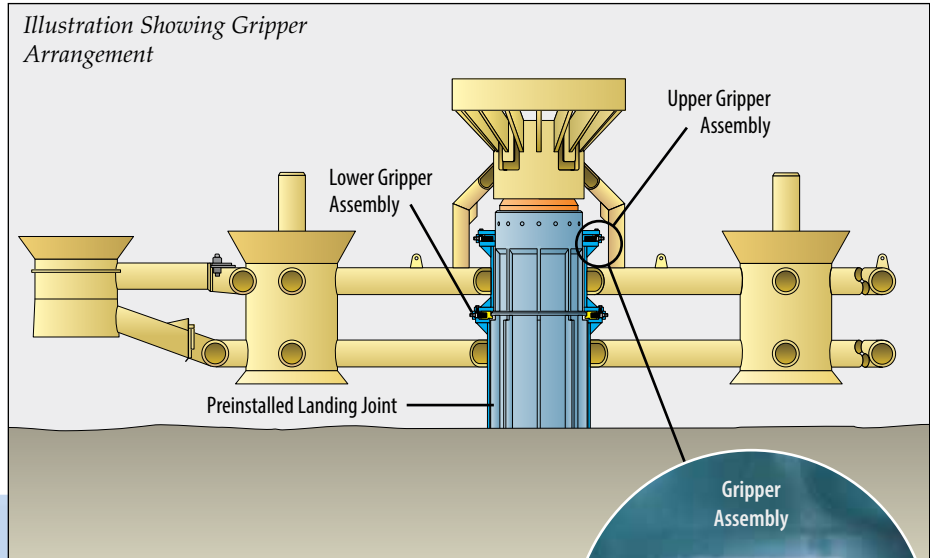

3-Well Conductor-Supported Template System

9-Well Conductor-Supported Template System



Dimensional Data

2-Well System (Minimum)

- Length.....11.25' or 3.4 m
- Width.....5' or 1.5 m
- Height.....5.3' or 1.6 m
- Weight in air3.4 tons or 3,100 kg

9-Well System (Minimum)

- Length.....23.6' or 7.2 m
- Width.....23.4' or 7.1 m
- Height.....10.5' or 3.2 m
- Weight in air29.8 tons or 27,000 kg

Bottom-Supported Template Systems

Bottom-Supported Template Systems can be used where ocean floor conditions are known to be stable and where the ocean floor inclination is less than 4°. DRIL-QUIP's Bottom-Supported Template Systems offer superior structural integrity and can accommodate a larger number of predrilled wells.

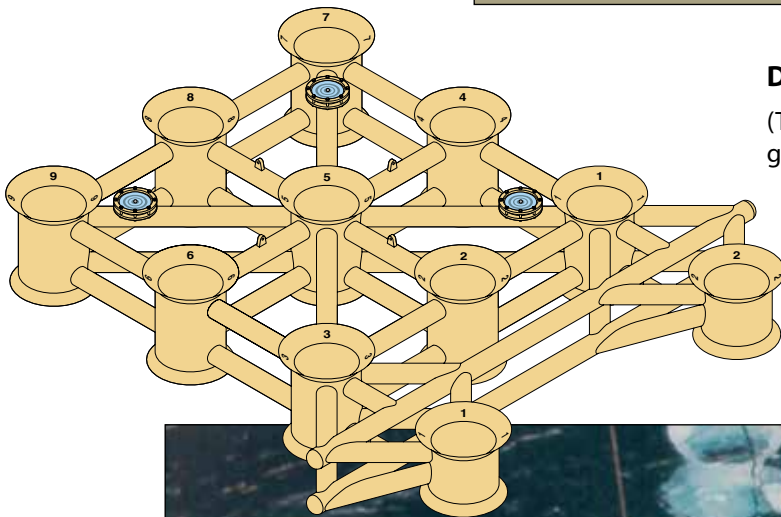
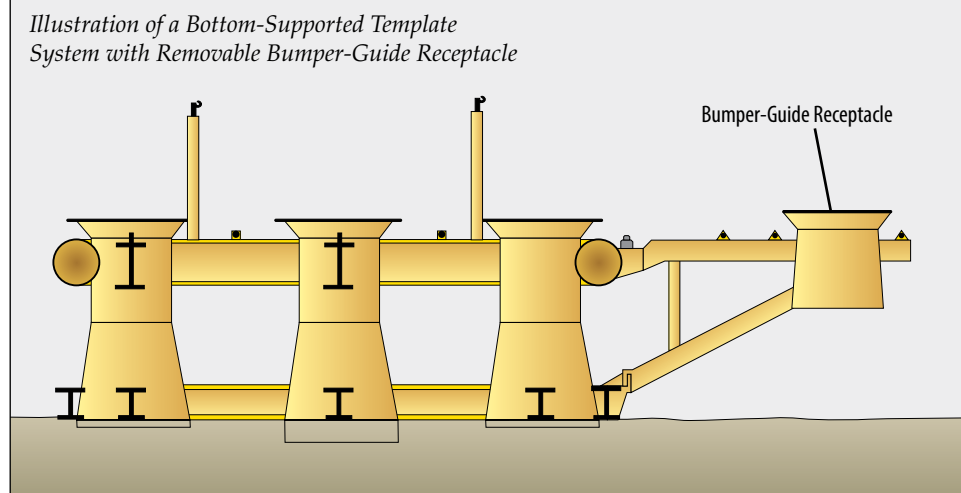

Dimensional Data

(Typical 9-Well Template System with two additional bumper-guide receptacles that accommodate 30" conductors)

Length.....	33.3' or 10.15 m
Width.....	24.5' or 7.5 m
Height.....	7.8' or 2.4 m
Weight in air.....	42.9 tons or 38,000 kg



MODULAR TEMPLATE SYSTEMS

Illustration of a Subsea Modular Template System

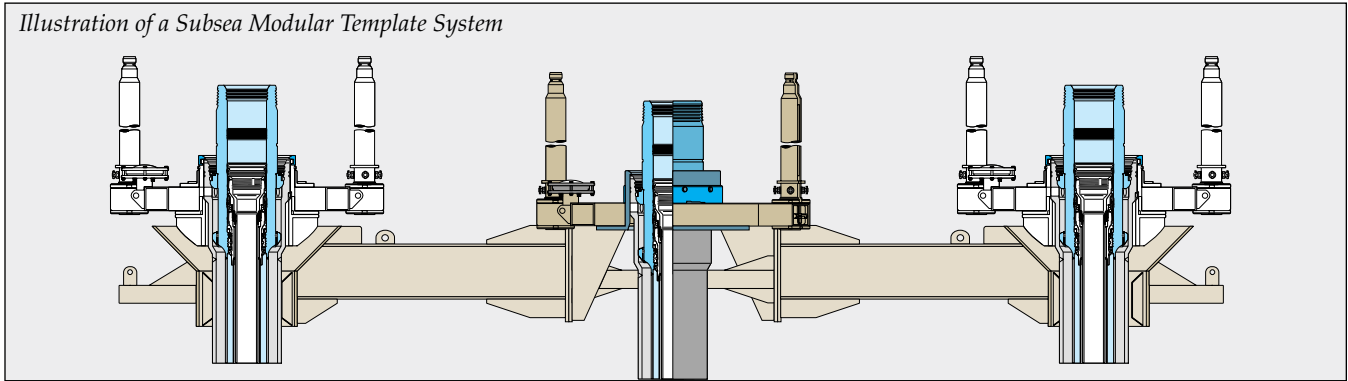

Modular Template Systems

The DRIL-QUIP Modular (or Spacer) Template Systems offer the flexibility to accommodate last-minute changes in the production program. This allows the operator to “build as you go,” eliminating wasted capital expenditures for unfilled template receptacles. The modular template system is generally used in conjunction with subsea drilling operations.

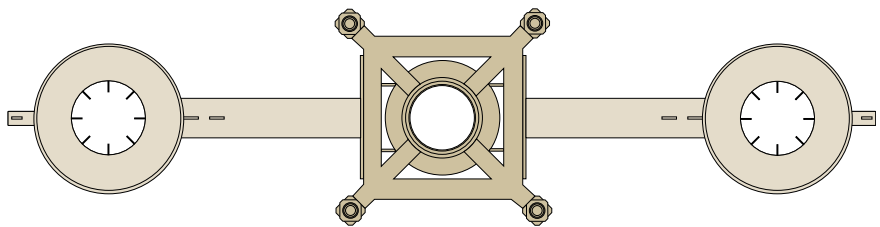

Top View of a Subsea Spacer Template



DRIL-QUIP employees performing a QC check on a Subsea Spacer Template



Fit-and-function test of a Subsea Tree on a DRIL-QUIP Modular Drilling and Production Template System

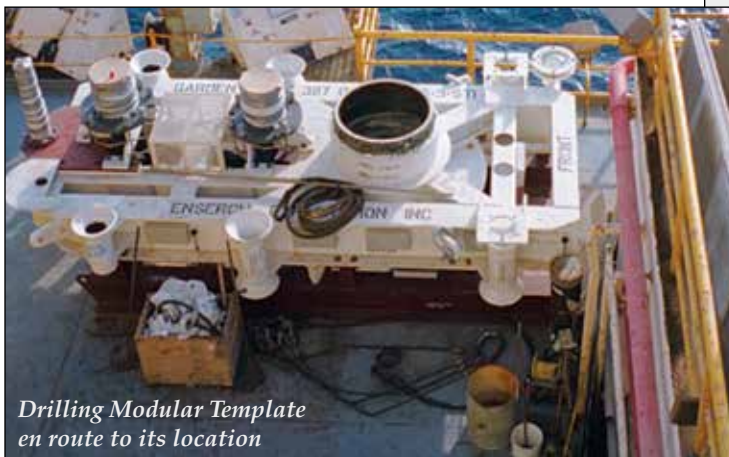

Drilling Modular Template en route to its location



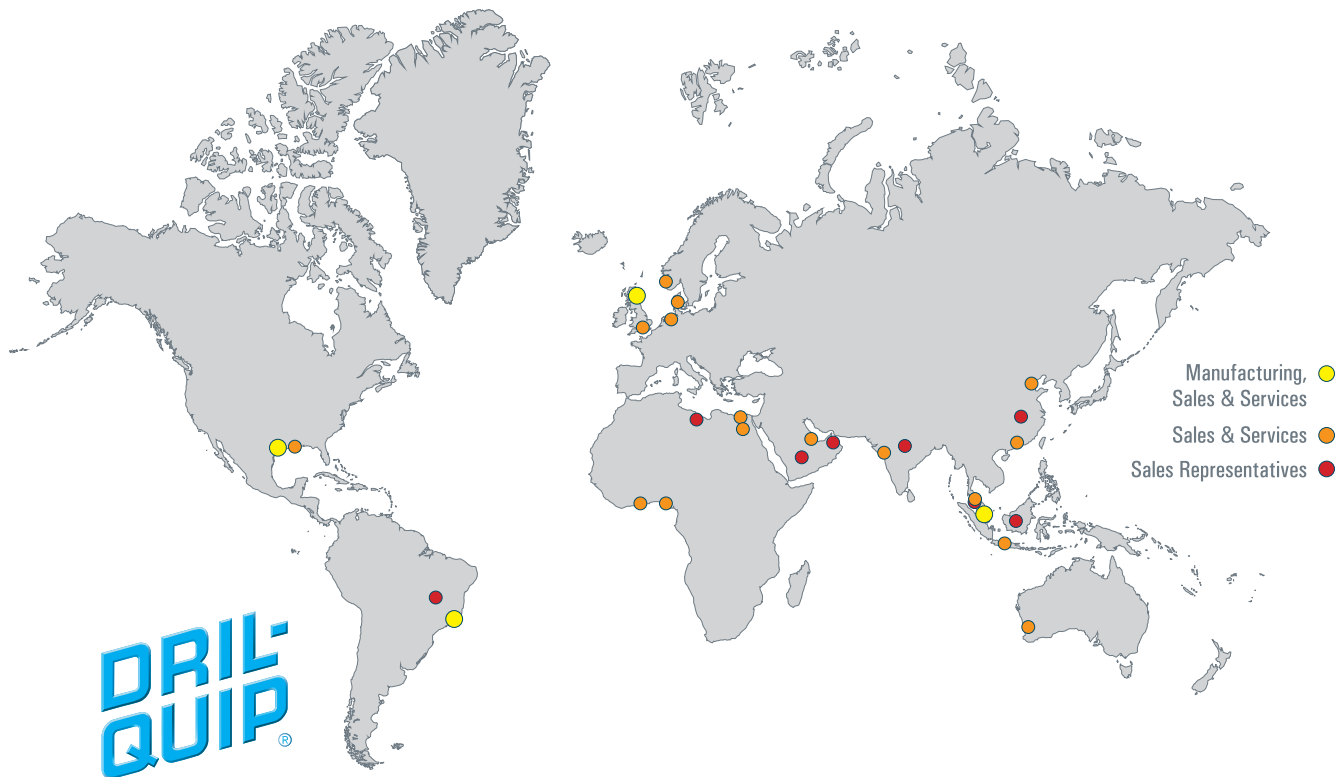

WORLDWIDE SALES & SERVICE

DRIL-QUIP WESTERN HEMISPHERE

DRIL-QUIP, Inc. World Headquarters
 6401 North Eldridge Pkwy.
 Houston, Texas 77041
 Tel (713) 939 7711
 Fax (713) 939 8063

DRIL-QUIP do Brasil, LTDA.
 Macaé, Brazil
 Tel (55) 22 2791 8950
 Fax (55) 22 2791 8989

DRIL-QUIP New Orleans
 New Orleans, Louisiana
 Tel (504) 522 5566
 Fax (504) 522 4426

DRIL-QUIP EASTERN HEMISPHERE

DRIL-QUIP (Europe), Ltd.
 Stonewood Park, Dyce
 Aberdeen, Scotland, UK AB21 7DZ
 Tel (44) 1224 727000
 Fax (44) 1224 727070

DRIL-QUIP London
 High Wycombe,
 Bucks, England
 Tel (44) 1494 601086
 Fax (44) 1494 601094

DRIL-QUIP Norway
 Stavanger, Norway
 Tel (47) 51 443700
 Fax (47) 51 443701

DRIL-QUIP The Netherlands
 Beverwijk, The Netherlands
 Tel (31) 251 22 9250
 Fax (31) 251 22 0044

DRIL-QUIP Denmark
 Esbjerg, Denmark
 Tel (45) 7518 0944
 Fax (45) 7518 0640

DRIL-QUIP Egypt
 Zahraa El-Maadi, Cairo, Egypt
 Tel (20) 22 753 8809
 Fax (20) 22 753 8907

Alexandria, Egypt
 Tel (20) 3 450 0507
 Fax (20) 3 450 0508

DRIL-QUIP Nigeria, Ltd.
 Port Harcourt, Nigeria
 Tel (234) 84 463866
 Fax (234) 84 463649

DRIL-QUIP (Ghana) Ltd.
 Takoradi, Ghana
 Tel: (233) 312 5384

DRIL-QUIP ASIA PACIFIC

DRIL-QUIP Asia Pacific Pte. Ltd.
 No. 80 Tuas West Drive
 Singapore, 638417
 Tel (65) 6861 0600
 Fax (65) 6861 5700

DRIL-QUIP China
 Shekou, P. R. China
 Tel (86) 75 5268 97137
 Fax (86) 75 5268 97134

DRIL-QUIP Oilfield Services (Tianjin) Co., Ltd.
 Tanggu, Tianjin, P. R. China
 Tel (86) 22 2580 7466
 Fax (86) 22 2580 7130

DRIL-QUIP Malaysia
 Kuala Lumpur, Malaysia
 Tel (60) 3 2168 4308
 Fax (60) 3 2168 4201

D.Q. Holdings Pty., Ltd.
 Perth, Australia
 Tel (61) 8 9322 8600
 Fax (61) 8 9322 8500

DRIL-QUIP Qatar
 Doha, Qatar
 Tel (974) 44389715
 Fax (974) 44417041

DRIL-QUIP Indonesia
 Jakarta, Indonesia
 Tel (62) 21 720 0612
 Fax (62) 21 720 1513